

FrontLine®

MARKETING INFORMATION FOR TODAY'S FEED PROFESSIONAL

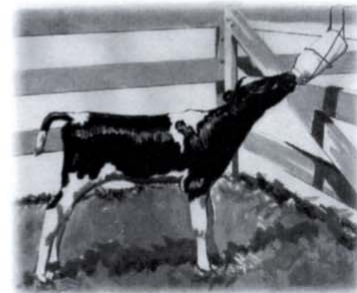

Mixing Milk Replacer, It's all in the Process

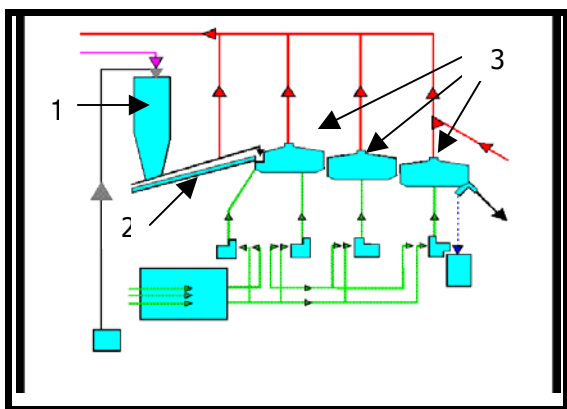

Milk Products uses a manufacturing process that instantizes, or agglomerates, dry blended powder to create a product that mixes easily, wets correctly, and stays in solution once mixed.

Our instantizing process begins at the hydrator tower, after the product has been blended. The heart of the instantizing equipment is the hydrator tower (1 above), where moisture is added to dry powder ingredients. As these particles fall down through the hydrator tower they stick to each other, forming snowflake-like agglomerates. The wet particles travel across the converter belt (2 above), providing time for the water to further soak into the powder particles. A fluid bed dryer (3 above) removes the added moisture. Dried agglomerated product is then sent to the packaging line. Once dried, these crystalline, agglomerated particles create capillary action when mixed with water, allowing easy mixing of the product.

Incremental Change to Our Manufacturing Process Results in Better Powder

Milk Products' goal in changing our manufacturing process is to provide a product that mixes even better than our current product, and incorporates well-emulsified fats to keep it uniformly dispersed in the milk replacer solution. Our new hydrator process applies an emulsion, or liquid blend, of protein and fat at the top of the tower, where only water was previously applied. To fully understand the process change, it is important to know some basic milk replacer terminology.

1. Wettability is a measure of how fast the powder breaks water tension, or drops below the surface of the water.

2. Mixability is a measure of how completely the powder goes into solution and stays in suspension. The majority of milk-replacer users are most concerned about mixability.

3. Separation is a measure of how much of the ingredients in a product separate from the rest of the solution. This includes ingredients that rise and float to the surface, and also those insoluble ingredients that sink to the bottom. Milk replacer solution should be uniform after mixing with no separation of ingredients.

How to Evaluate What You See

When mixing product, take care to watch how the product wets, or sinks into the water. Wettability is variable, with some competitor products wetting too quickly and others not wetting at all. Products that

wet too quickly may sink directly to the bottom of the pail or tank without enough time to dissolve. Products on the market that don't wet may not have a chance to dissolve into solution; instead the powder floats on top of the water. Both conditions, fast or slow, require more mixing than our powder that gently dissolves as it wets. The new agglomeration process produces powder particles with larger surface area that look drier and more crystalline. This incremental change in our process results in uniform powder agglomerate that is easy to mix and is less dense, or fluffier, than other products manufactured in the industry.

Mixing Characteristics

Milk Products' milk replacer is still designed to mix in warm water (110-120° F). The new process produces milk replacer powder that looks drier and more crystalline when compared to our old process and also other products on the market today. This powder will break the water tension, or wet into solution, with very little mixing.

Mixing Tips:

- Mix milk replacer powder into warm water (110-120° F).
- Whisk or mix until milk replacer is in solution taking care not to over mix.
- Mix milk replacer by following consistent procedures and protocols.

In Summary

The diversity of the milk replacer market, from single calf feeders hand mixing, to large commercial operations feeding thousands of calves per day, requires a product that can mix easily, wet well and perform under a variety of conditions. Our unique manufacturing process has been designed to provide customers with powder that wets correctly, mixes easily, and remains in solution once mixed.